

Review Paper:**Methodological Dimensions of Transcranial Brain Stimulation with the Electrical Current in Human**Maryam Rostami^{1,4}, Mehrshad Golesorkhi^{1,2,5}, Hamed Ekhtiari^{1,2,3*}*1. Translational Neuroscience Program, Institute for Cognitive Science Studies, Tehran, Iran.**2. Neuroimaging and Analysis Group, Research Center for Molecular and Cellular Imaging, Tehran University for Medical Sciences, Tehran, Iran.**3. Iranian National Center for Addiction Studies, Tehran University for Medical Sciences, Tehran, Iran.**4. Department of Biomedical Engineering, Amirkabir University of Technology (Tehran Polytechnic), Tehran, Iran.**5. Department of Computer Science, School of Mathematics, Statistics and Computer Science, University of Tehran, Tehran, Iran.*

Article info:

Received: 16 October 2012

First Revision: 10 February 2013

Accepted: 20 May 2013

Key Words:Transcranial Electrical Stimulation (tES),
Transcranial Direct Current
Stimulation (tDCS),
Transcranial Alternating Current
Stimulation (tACS),
Non Invasive Brain Stimulation
(NIBS).**A B S T R A C T**

Transcranial current stimulation (TCS) is a neuromodulation method in which the patient is exposed to a mild electric current (direct or alternating) at 1-2 mA, resulting in an increase or a decrease in the brain excitability. This modification in neural activities can be used as a method for functional human brain mapping with causal inferences. This method might also facilitate the treatments of many neuropsychiatric disorders based on its inexpensive, simple, safe, noninvasive, painless, semi-focal excitatory and inhibitory effects. Given this, a comparison amongst different brain stimulation modalities has been made to determine the potential advantages of the TCS method. In addition, considerable methodological details on using TCS in basic and clinical neuroscience studies in human subjects have been introduced. Technical characteristics of TCS devices and their related accessories with regard to safety concerns have also been well articulated. Finally, some TCS application opportunities have been emphasized, including its potential use in the near future.

1. Introduction

Throughout the previous decades, therapeutic stimulation modalities have made a great influence on paving the way towards treating a number of neuropsychiatric disorders. In the competitive field of achieving different ways to modulate the brain activity in a certain direction, there have been some other types of brain stimulation techniques including TMS (Transcranial Magnetic Stimulation), ECS (Electro Convulsive Stimulation) and DBS (Deep Brain Stimulation) in parallel with the presently focused technology, TCS (Transcranial Current Stimulation). TCS, the re-emerged way of brain stimulation, had been forgotten for a while after

its discovery while it has been taken into consideration over the previous years. Hence, plenty of studies, pilot or proof-of-principle, have been carried out to investigate whether it can eventually result in a clinically approved application or not. Actually, a brilliant progress has been made and is still moving towards accomplishment in order to have its efficacy depicted as a beneficial method in both basic and clinical neuroscience. The present article provides a technical comparison among the recent modalities of brain stimulation and presents an introduction to the currently commercially available TCS devices illustrating some of their technical characteristics. Moreover, a brief discussion on TCS electrodes in addition to applications in basic studies where this method reveals as a potential method of choice will be made.

*** Corresponding Author:**

Hamed Ekhtiari, MD,

Translational Neuroscience Program, Institute for Cognitive Science Studies.

Address: No. 18, Pezeshkpour Alley, Vali-e-asr Avenue, Tehran, 1594834111, Iran. Tel: +98 21 88802065, ext:119

E-mail: h_ekhtiari@razi.tums.ac.ir/ h.ekhtiari@iricss.org

2. Historical Overview

The rudimentary idea of ‘therapeutic electricity’ is relatively old if we consider the application of some animals, fish for instance, to treat some neurological disorders (Priori, 2003). Luigi Galvani and Alessandra Volta were two of such researchers who benefited from an animal source of electricity to do tDCS-based researches. As such, many fundamental studies were made until the 19th century by which TCS was developed as a technical method of brain stimulation. Eduard Hitzig (1867) who was one of the pioneers in utilizing the constant current to treat depression happened to notice involuntary movement of the subjects’ eyes when doing his experiments. In collaboration with an expert anatomist, Gustav Fritsch, Hitzig conducted other studies to verify such phenomenon. He ultimately demonstrated the correlation between stimulating different cortical areas and distinct responses in the contralateral limb (Gross, 2007; Pauly, 1983).

Later, Bishop and Erlanger (1926) conducted a related study on the effect of polarity on motor neurons, which led to the fact that the anodal stimulation would cause an increase in the membrane potential difference, while the cathodal one would result in a decrease of the same (Bishop & O’Leary, 1950). In the 1960s, Bindman discovered that a 0.1–0.5 μA of electrical current would sufficiently produce a neural excitability shift in rat’s cortex which remained for some hours after the stimulation was terminated (Bindman, Lippold, & Redfean, 1962, 1964). Such an incidence evoked a considerable enthusiasm to modulate the brain excitability through brain polarization, which would cause a long-lasting result at the expense of a relatively short duration of stimulation.

Consequently, Lippold and Redfean found many benefits of brain polarization to treat depressive disorders in patients, especially in those who had failed to respond to prior methods, including ECT (Electroconvulsive Therapy). This became more evident following the experiments on rats’ cortex in collaboration with Bindman (Bindman, et al., 1964; Lippold & Redfean, 1964; Redfean, Lippold, & Costain, 1964). Taken in to account that all subjects were healthy, these investigators found that the anodal stimulation increases the alertness, mood and motor activity, while the cathodal one results in apathy and quietness (Lippold & Redfean, 1964; Redfean, et al., 1964). Costain continued to carry out some controlled experiments to further prove the efficacy of such a method (Costain, Redfean, & Lippold, 1964). However, the desire to hold on the studies disappeared while trying to reach the analogous results (Arfai, Theano, Montagu, & Robin, 1970; Hall, Hicks,

& Hopkins, 1970; Lifshitz & Harper, 1968) until the 1990s (indeed from 2000s) that TCS came back to both therapeutic and cognitive studies, specifically in human subjects. This approach started to offer new hopes after disappointing results came from pharmacological studies where psychotropic drugs failed to control refractory patients’ symptoms.

3. Mechanism of Action

Based on recent neuroimaging studies, serving as a helpful tool for improving the efficacy of stimulation according to determination of targeted area, some main effects have been discovered to better understand the mechanism of tDCS. The imaging modalities such as positron emission tomography (PET) (Lang et al., 2005), functional magnetic resonance imaging (fMRI) (Baudewig, Nitsche, Paulus, & Frahm, 2001) and magnetic resonance spectroscopy (Arul-Anandam & Loo, 2009; Rango et al., 2008) can be considered in this category. These methods have proven some changes in the regional blood flow, glutamatergic neurotransmission and membrane function after stimulating the brain regions distal to the sites involved.

Noteworthy is that, the tDCS potentially changes the spontaneous firing rates without influencing the action potentials (Arul-Anandam, Loo, & Sachdev, 2009) and this is mainly due to the current densities being less than the action potential threshold of cortical neurons (Tehovnik, 1996; Wagner et al., 2007). Some studies have indicated that tDCS works successfully in stimulation since it changes the resting membrane potential while blocking the sodium ion channels through special drugs in order to decompose the changes in motor-evoked from the resting potential (Liebetanz, Nitsche, Tergau, & Paulus, 2002; Nitsche et al., 2003).

4. Different Brain Stimulation Modalities

Currently, there are a variety of brain modulation methods utilizing the electric and magnetic fields in order to alter the brain’s activity. Some of these include, ECT (Electroconvulsive Therapy), VNS (Vagus Nerve Stimulation), TMS (Transcranial Magnetic Stimulation), DBS (Deep Brain Stimulation), Ultrasonic and Photonic stimulation.

In table 1, some of these modalities are being compared based on the interface, waveform and their general characteristics, stimulating machine and the approximate duration of stimulation. This is to provide an insight into technical properties of such methods. These descriptions partly prove the privileges of TCS over the other modalities.

For TCS in particular, the interface is defined as a saline soaked cotton pad containing rubber electrodes for conventional stimulation while some tiny set of electrodes are used for High-definition type. Conventional type electrodes' shape is usually square or rectangular and made of the materials mentioned. The working voltage

of the TCS device here describes the threshold of stimulation in which the device is turned off in order not to exceed the outcome current. Also, the power consumption of the device has been noted as one of the possibly-stated characteristics. The duration also states the required period of time for the process to be carried out.

Table 1. Technical characteristics of different brain stimulation modalities

	Interface				Waveform		Stimulating Machine			Duration
	Shape	Size	Material	Other properties	A ¹	F ²	V ³	C ⁴	P ⁵	
TMS (Griskova, Hoppner, Ruksenas, & Dapsys, 2006; Speer et al., 2000; Wagner, Valero-Cabre, & Pascual-Leone, 2007)	Magnetic coil				Magnetic pulse		400-10K	4k-10k	5M	-
	Single circular loop/figure-8 shaped	4-9 cm diameter (10-20 winding turns)	Wound copper wire	15-150 μH Inductance	1-4 Tesla	1-5 (Low); 10-20 (High)				
tDCS (Minhas et al.; Wagner, Valero-Cabre, et al., 2007)	Saline soaked cotton pads/ sponge patches covered with conductive gel/ array electrodes				DC current		To 66.7	To 2m	-	5-30 min.
	Square ⁶ Disk/pellet/ ring ⁷	20-35 cm ² ⁸ / 12 cm ² ⁹	Cotton, Ag/AgCl, Ag	Current density: 24-29 μA/ cm ²	0.5-2 mA	-				
tACS (Minhas, et al.; Wagner, Valero-Cabre, et al., 2007)	Saline soaked cotton pads/ sponge patches covered with conductive gel/ array electrodes				Pulse train Square		30-35 p-p	0.1-4 m	-	5-30 min.
	Square ¹⁰ Disk/pellet/ ring ¹¹	25-35 cm ² ¹² /12 cm ² ¹³	Cotton, Ag/AgCl, Ag	Current density: 24-29 μA/ cm ²	0.5-2 mA	0.5-167 k				
DBS (Butson & McIntyre, 2006; Gimsa et al., 2005)	Metal Electrodes				Rectangular Pulse		-10 - -3	0.01-2 m	-	2-7 years (battery re-charge needed)
	Bar shaped	Approximately 1.27mm diameter, 1.5mm height, 5.98 mm ² surface	Stainless steel, Pt/Ir	Having conductivity 0.2 S/m	3 v	100-185				
ECT (Scott, 2009)	2 electrodes				Rectangular Pulse		600-1000 mC charge needed (Several hundred watts)			1-6 sec.
	cylinder having electrodes (relatively similar to TCS) in the end				~ 800 mA	~ 100				
Photonic (Zhang et al., 2009)	Red and Infrared light optrodes				650-900 nm Wave-lengths	~ (100 ms) ⁻¹	-	-	To 6.6 mW	Different ¹⁴
	Bar-shaped	0.5-1.5 mm height	Platinum covered	Involving a volume of ~ 7.57 *10 ⁵ um ³						
Ultrasound (Yoo et al., 2011)	Ultrasound Transducer				Ultrasound pulse		-			1-2 sec.
	Single Array	Variable	-	-	Isppa ¹⁵ = 12.6 W/cm ²	690 PRF ¹⁶ = 10 Hz				

1. Amplitude
 2. Frequency (Hertz)
 3. Voltage (volt)
 4. Current (Ampere)
 5. Power (Watt)
 6. Conventional tDCS
 7. High definition tDCS
 8. Conventional tDCS
 9. High definition tDCS
 10. Conventional tDCS
 11. High definition tDCS
 12. Conventional tDCS
 13. High definition tDCS
 14. Differs from 1 second at a distance of 5 feet, to 40 minutes in direct contact with the skin
 15. Intensity of spatial-peak pulse-average
 16. Pulse repetition frequency

5. TCS Requirements

Prior to start the procedure, the availability of the required materials should be carefully ensured. In the following, a set of essential materials is mentioned:

- TDCS device; the main component of the stimulation process comprises an electric apparatus which delivers the considered power to the target.
- Two sponge electrodes; the outer layer of the interface between the involved tissue and the power applying device.
- Two conductive rubber electrodes; the inner part of the sponge electrodes, supposed to deliver the applied current as a conductive medium.

- NaCl solution; the conductive solution used to obtain a better contact.
- Two rubber head bands; used to fasten and fix the electrodes on subject's head.
- 9V Battery (2x); the source from which the required power is generated.
- Cables; placed between the device and the electrodes, used to guide the electric power to the electrodes.
- Measurement Tape; used to determine the aimed place of stimulation and to locate the electrodes in order to have the desirable montage.

The following picture illustrates the required components of a common TCS device.

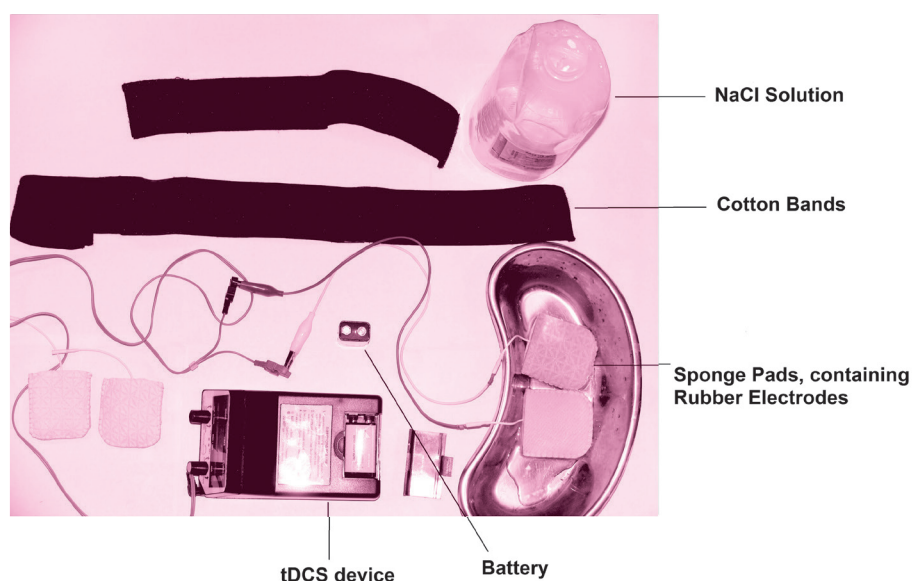

Figure 1. The preliminary TCS requirements

NEURSCIENCE

6. TCS Machine

Presently, there are many commercial types of TCS stimulators which have enabled some clinical and research applications. They can be categorized as off-label and on label devices. The on-label devices are particularly designed and then used for TCS and mostly tDCS due to their applicability for clinical trials, while the off-labels are used for TCS in addition to some other applications. In the following categories, there will be a brief description on some of these items, prior to summarizing them in table 2.

The front panel of an ideal TCS device is illustrated in the following figure to provide a view of its required parts.

On-Label Devices

6-1) Eldith stimulator – direct current (DC) stimulator used in clinical trials, in a hospital setting with the supervision of specialized personnel.

6-2) HDC series – programmable and portable device for tDCS treatment. The latest in this series is the HDCstim device.

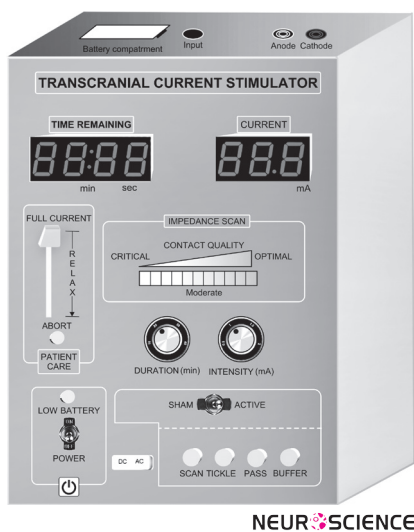

Figure 2. A sample tDCS device; the “Time Remaining” part reverse counts the preset time; the “Current” part indicates the applied current intensity; Patient care can be dedicated to manually increase or decrease the intensity and abort the whole process if necessary; the “Impedance Scan” estimates the electrodes contact impedance and verifies its quality to optimize the place of electrodes, it will be optimal if the whole triangle gets colorful; “Duration and Intensity” knobs account for the preliminary stimulation adjustment. When set to the Active mode, Scan (scans and checks the contact’s impedance), Tickle (applies an excess amount of current in cases of insufficient contacts), Pass (enables the main process of stimulation) and Buffer (isolates the device and electrical fields from environmental inputs –e.g. MRI) options should be adjusted, otherwise Sham mode should be selected; AC or DC types can be selected with the pertaining switch.

6-3) Soterix Medical stimulator: direct current (DC) generator used specially for delivering the required current to the target of the stimulation in both conventional and high definition type of stimulation.

6-4) Fisher Wallace Stimulator: a portable, safe and effective way for delivering a gentle, patented electrical current via sponge electrodes.

6-5) Trans-Cranial Stimulator: a portable, safe and easy-to-use device for delivering direct current to the scalp.

6-6) Starstim: a noninvasive wireless tCSneuro-stimulator used to perform electrical stimulation along with EEG monitoring.

Off-label TCS Devices

6-7) CESta – a high quality cranio-electro stimulation (CES) device capable of being promoted for use as tDCS, Micro-TENS or as a colloidal making device.

6-8) ActivaDose II Iontophoresis Delivery Unit – a delivery unit used to administer the prescribed soluble salts or other drugs into the body for medical purposes as an alternative to hypodermic injection.

Table 2. Summary of the commercially available TCS devices.

Usage type	On-label						Off-label	
Device Trade-mark	Eldith (neuroConn)	HDC	Soterix	Fisher	Trans-Cranial-Technologies	Neuro-electrics	CESta	Activa-dose II
Different available types	<ul style="list-style-type: none"> •DC-Stimulator •DC-Stimulator Plus •DC-Stimulator MR •DC-Stimulator MC 	HDCstim (mostly)	<ul style="list-style-type: none"> • 1x1 tDCS-Stimulator • 4x1 Two Channel Stimulator • MxN Advanced System 	Fisher Wallace Stimulator	Trans-Cranial	Starstim	CESta Stimulator	Activadose II Iontophoresis Delivery Unit
Stimulation Modalities	Conventional tDCS/ tACS	Conventional tDCS	Conventional tDCS/ tACS , HD-tDCS	Conventional tDCS/ tACS	Conventional tDCS	HD-tDCS	Conventional tDCS	Conventional tDCS
Company Reference	www.neuroconn.de/tdcs_en/	www.magstim.com/tdcs	www.soterixmedical.com	www.fisher-wallace.com	www.transcranial.com	http://neuro-electrics.com/	www.mindalive.com/2_2	www.activatekinc.com/

Eldith Stimulator

There is a variety of options in this category based on the DC/AC stimulation type, single/multi-channel device, clinical/personal at home use, etc. It should be noted that the basis of the design remains the same, although some physical and practical aspects of the device vary.

6-1-1) DC-Stimulator for tDCS

Supplied with a microprocessor-controlled constant current source, it serves two main modes of stimulation, including single (with a continuous stimulation, configurable fade-in and fade-out) and pulse one (cyclic turning on/off for the stimulation with a configurable pulse width and interval).

6-1-2) DC-Stimulator Plus for tDCS and tACS

Presenting two stimulation types of DC (unipolar) and AC (bipolar) in different modes of active and sham stimulation, four stimulation modes have been provided: ‘‘tDCS’’(continuous stimulation, adjustable current of 0 to $\pm 4,500$ μA , duration 15-1,800 s, duration of fade-in/ fade-out 1-120 s), ‘‘Pulse’’ (cyclic turning on/off of stimulation, duration of complete pulse cycle/interstimulus interval (ISI) 300-2,000 ms, pulse width 200-(ISI-100), number of pulse cycles 1-500), ‘‘Sinus’’(bipolar sinus waves adjustable current of 0 up to 3,000 μA , offset 0- $\pm 1,000$ μA , frequencies of 0-250 Hz, adjustable phase 0-360 degree, duration 0-480 min), ‘‘noise’’(normally distributed broadband low and high frequency noise, adjustable current of up to 1,500 μA , offset 0- $\pm 1,000$ μA , duration 0-1,800 s, fade-in/fade-out period of 0-120 s)

6-1-3) DC-Stimulator MR

Equipped with the same facilities of the previous models, an extra amenity of MRI compatibility has been added, since no interference of the fMRI images during EPI sequence had been observed.

6-1-4) DC-Stimulator MC

7-Equipped with 4 programmable, microprocessor-controlled constant current sources using independent channels, it can serve various stimulation types including tDCS, tACS, CES¹⁷, GVS¹⁸ and tRNS¹⁹. This device is provided with the aforementioned modes of stimula-

tion, including continuous, cyclical switching on and off, sinusoidal stimulation and their combination. The device is also fMRI compatible and neither makes nor takes any interference.

HDC Stimulators - HDCstim

This device has not only been provided with the previous models’ facilities, but also equipped with some other accessories in order to monitor the impedance of the contacts, to alarm in the case of insufficient contact. Generally, it has the ability to deliver DC stimulation to the target tissue, as well as the others.

Soterix Medical Stimulator

Offering a variety of devices, the overall idea of the design mostly remains the same as using a current generator. Unlike the others, it is equipped with the high definition type and benefits from some excess modes to technically simplify the whole process, such as monitoring the contact efficiency of the electrodes.

6-3-1) 1×1 tDCS Low-Intensity Stimulator

The Soterix Medical 1*1 line of low-intensity tDCS stimulator is mainly designed to produce low levels of DC current running through the two electrodes, the anode and the cathode placed on the target. It has several features to improve the safety of the process and to promote the subject comfort. These include, TRUE CURRENT, SMARTscan, RELAX and Pre-Stim TICKLE. In the SMARTscan mode, a continuous visual illustration of the electrodes’ quality is provided, before the stimulation or during it. In TRUE CURRENT mode, the supplied current is clearly depicted. In the TICKLE mode, a very weak current prior to tDCS may be applied in order to condition the skin. The RELAX mode also allows the clinician to reduce the current less than its preset given some exceptions such as the subject feedback. This includes two types of devices, the simple one and the ‘clinical trials’ type which can be used to more conveniently perform many clinical investigations.

6-3-2) 4×1-C2 Multi Channel Stimulation Interface

Being an accessory to the isolated 2-channel stimulator, it is designed to be used with 5 leads where 4 leads (colored) are connected to an output of the stimulator,

17. Cranial Electrical Stimulation

18. Galvanic Vestibular Stimulation

19. Transcranial Random Noise Stimulation

and the remaining lead (white) is connected to the other output of the tDCS stimulator. This setup benefits from up to four modes including scanning, pass, tickle and buffer. In the first mode, the impedance between the surface of the electrode and the skin is scanned to find the optimized place of contact leading to a better current division among the electrodes.

In the second mode, the current will be delivered to the surface of the scalp and in the third mode, a small current will be applied through a selected electrode to lower its impedance if necessary. In the buffer mode, the electrodes will be isolated from the main circuitry of the apparatus, enabling the device compatibility with MRI and TMS.

6-3-3) M×N Advanced Neuromodulation Systems

As a non-invasive neuromodulation platform developed in M×N HD-tDCS stimulators (8-channel and 4-channel), this setup provides the clinician with control of electrode placement and the current, resulting in a novel noninvasive targeting. As such, the HD-targets and HD-explore systems enable the investigators to carry out automatic or manual dose optimization. The MXN system can be configured for effective DC stimulation without reportable sensation in most subjects. This system consists of multiple electrodes arranged in a special montage (4×1 for instance), resulting in more focal current delivery to the cortex.

Fisher Wallace Stimulator

This device is specifically equipped with an AC delivering source which can supply 0-4 mA output current. It has been designed to work on patented frequencies of 15/500/15000 Hz with the pulse width of 33 microseconds, where the maximum charge per pulse will be 0.13 micro coulombs. The setup has also been provided with On/Off Time Per Burst of 50 milliseconds and 16.7 milliseconds, respectively. Its configuration can be simply changed to tDCS application for investigational studies. It is mainly based on conventional tDCS model having saline soaked sponge pads and its current density can be altered using a knob which can both be used to determine the current intensity or turn the device on/off.

Trans-Cranial-Technologies

This device can provide a direct current of 0.5 to 2 mA in 0.1mA increments; it can be used for up to 30 minutes with countdown current display. Meanwhile, it can monitor and display actual current and electrode quality;

it also ramps up in a slow manner to raise the subject's comfort through conditioning the skin. Moreover, automatic abort has been added in cases of excessive resistance to prevent skin irritation.

Starstim

Multi-channel programmable tCS is capable of performing current-controlled tDCS, tACS and tRNS in sham or user-defined waveforms. It can stimulate and record at the same time using the same electrodes which provides the user with a visualized EEG monitoring. It is equipped with EEG data output and Bluetooth 2.1 communication set, while is compatible with different operating systems of Windows and MAC. Finally, it can provide a maximum current of ± 2 mA per electrode while recording EEG signals at a specific sampling rate.

CESta Stimulators

Analogous to the prior models, it is equipped with the essential accessories to deliver DC current to the aimed tissue. It has the ability to check the connections to estimate the skin impedance in order to find the possible deficiencies in the electrodes' contact. It is also provided with some presumed function libraries, prepared in some tables, to determine the required specifications of stimulation according to the patient's disorder.

Adding to the above specifications and function, Micro-TENS stimulation, tDCS, Colloidal Silver production and Synchronization with the company's Digital Audio-Visual Integration Device (DAVID) and other types of Portable and Lightweight (PAL, PAL36) devices can be considered as CESta stimulator's functions.

ActivaDose II Iontophoresis Delivery Unit

The ActivaDose II Iontophoresis Delivery Unit is indicated for the administration of soluble salts or other drugs into the body for medical purposes as an alternative to hypodermic injection in situations when it is advisable to avoid the pain of needle insertion and drug injection and to minimize the infiltration of carrier fluids, or to avoid the damage caused by the needle insertion when tissue is traumatized.

It only works at a continuous stimulation mode and is able to provide the required current up to 4 mA in a ramp up manner with an adjustable duration.

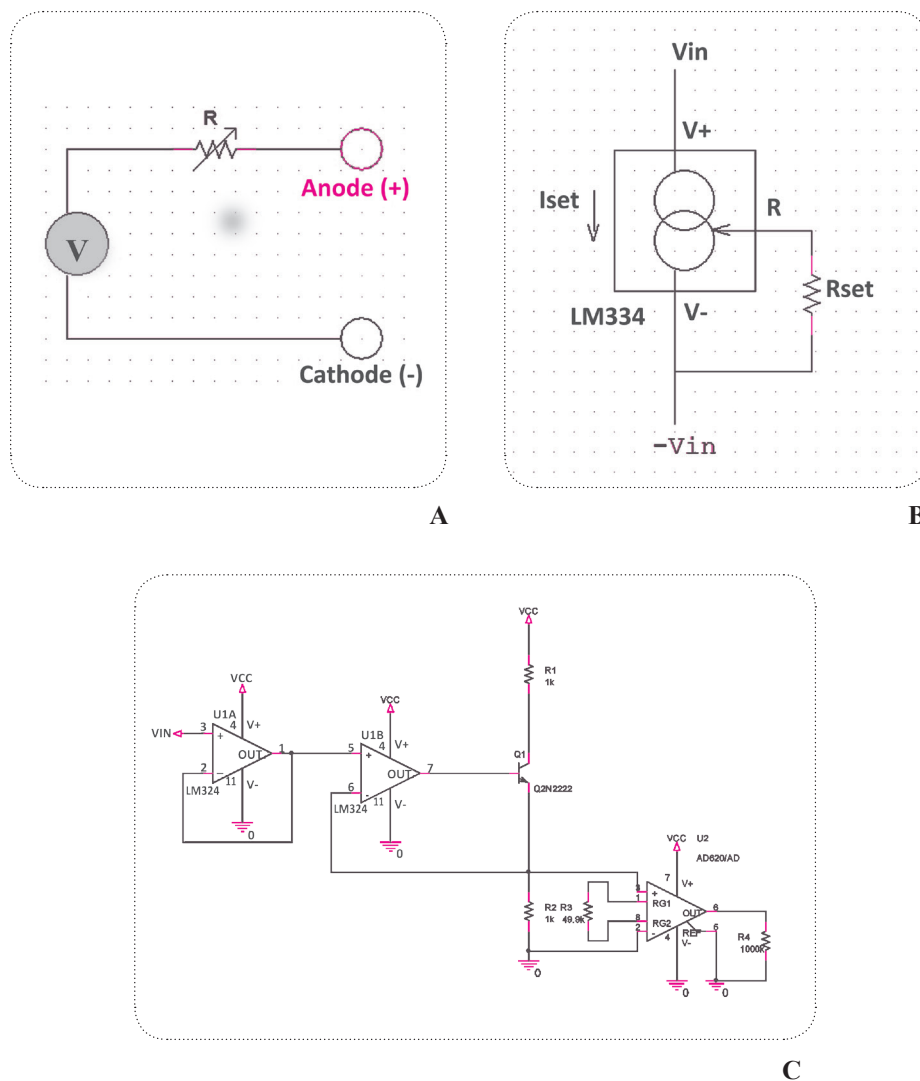

NEURSCIENCE

Figure 3. TCS Fundamental sample circuits a) Circuit model, b) Integrated circuit implementation using LM334, c) Feedback implementation.

7. Circuitry and Schematics

The key feature in designing a TCS device is the use of an adjustable current regulator, which contains different parts of electronic components. A simple tDCS device can be assumed as a current source. Voltage and current regulators, LM334 and LM317 for instance, which usually provide an output of constant voltage or current respectively, regardless of the changes in other characteristics of the circuit including input voltage current or load conditions are used to supply the required output current for the stimulation process. There are two main implementation techniques: linear and switching each of which has some advantages and disadvantages. Simpler design and lower cost are the most important advantages

of the linear current regulator, in contrast to switching types which have complicated design and more electronic parts. A favorable efficiency and low weight of switching regulators are the key advantageous factors for such a portable device. A linear regulator employs an active (BJT or MOSFET) pass device (series or shunt) controlled by a high gain differential amplifier whereas a switching regulator converts the DC input voltage to a switched voltage applied to a power MOSFET or BJT switch.

Common switching regulators mainly include Buck (step-down), Boost (step-up), Buck/Boost (step-down/step-down). Moreover, the TCS apparatus usually retains the advantage of boost topology in which the volt-

age will rise until it reaches the final threshold to supply the aimed current.

Linear regulators generally include integrated current source (LM334) and Operational amplifiers.

Another common fashion of generating current is using voltage to current converters which is used by some commercially available devices. In this method, an input voltage will be modified in order to transform into the adjusted current.

8. Conventional vs. High Definition TCS

There are mainly two separate types of transcranial current stimulation techniques including conventional and High-definition TCS. Conventional transcranial direct current stimulation (tDCS) supplies weak direct currents (260 mA-2 mA) applied to the scalp via rectangular sponge patches (nominally 25-35 cm²) covered with conductive gel (F. Hummel et al., 2005; Iyer et al., 2005; Marshall, Molle, Siebner, & Born, 2005; Nitsche & Paulus, 2000). Once conventional type had been invented and used to perform studies to investigate the efficacy of TCS, it showed to suffer from poor spatial precision as it involves a broad region of cortex owing to skull dispersion. A newer design called high definition tDCS (HD-tDCS) provides a focal current delivery to discrete regions of cortex and to avoid diffuse spatial resolution. In this approach, multiple (more than two) smaller gel electrodes, instead of using two large pads, are used to target specific cortical structures. The HD-tDCS can be performed via different montages. One of the possible electrodes configurations is the 4×1 HD-tDCS montage in which 4 electrodes are placed around a central one; thus, a set of 5 electrodes is used to deliver the required current to the cortex, which results in higher focality as compared to the conventional type (Caparelli-Daquer E et al., 2012). Both types tend to modulate the brain activity to cause a decrease or an increase in pain and sensory experience as well as offering some other possible effects (Borckardt et al.).

9. Alternating vs. Direct Current Stimulation

Since more than a decade ago, abundant studies with various designs have been carried out to investigate the possible effects the low-intensity (sub-threshold) current stimulation on cortical excitability, but great proportion of it has been dedicated to direct rather than alternating current stimulation. In fact, the only difference they have is regarding their current type, which is simply alternating in tACS and direct in tDCS while the required ap-

paratus and other accessories remain the same. The two ways often cause different effects in brain and its functions, the main objective of the performed studies.

The recent studies performed in the previous decade (2000s to 2010s) reveal the tDCS efficacy through various achievements including, significant effects on visual recognition memory task in Alzheimer disease (Boggio et al., 2009), decreasing tics in two patients with Tourette syndrome (Mrakic-Sposta et al., 2008), decrease in craving for alcohol (Boggio, Sultani, et al., 2008), significantly reduced craving for some foods (Fregni et al., 2008), reduction in subjects' propensity to punish unfair behavior (Knoch et al., 2008), increased recognition memory (Ferrucci et al., 2008), significantly reduced depression scores (Boggio, Rigonatti, et al., 2008; Fregni, Boggio, Nitsche, et al., 2006), increased sleep efficiency and decreased arousals (Roizenblatt et al., 2007), decreased reaction time (Boggio et al., 2006) and improvements of motor functions (Fregni, Boggio, Santos, et al., 2006) in Parkinson's Disease and decreases in Epilepsy seizure frequency (Fregni, Thome-Souza, et al., 2006), improvement in accuracy of the picture naming task (Monti et al., 2008), decreased reaction time (F. C. Hummel et al., 2006) and significant motor improvement (Boggio et al., 2007; Hesse et al., 2007) have been the outstanding attempts in Stroke patients' clinical trials in addition to the novel opportunities in the future perspective.

Over the recent decades, some alternating current stimulation clinical trials have investigated the visual phosphene induction in healthy subjects (Kanai, Chaieb, Antal, Walsh, & Paulus, 2008), the improvement in implicit motor learning task in healthy subjects (Chaieb, Antal, Terney, & Paulus) and assessed this technique's effects on patients suffering from generalized anxiety disorder (Roy-Byrne et al.). Additionally, this approach has succeeded to lead to a significant difference in the average pain intensity in spinal cord injury patients (Tan et al., 2006), (Capel, Dorrell, Spencer, & Davis, 2003), significant difference in beta-endorphin levels (Gabis, Shklar, & Geva, 2003), EEG alterations in alpha and beta band frequencies (Schroeder & Barr, 2001) and finally, improvements in attention (Southworth, 1999).

10. TCS Electrodes

One of the noteworthy aspects of a TCS study is indeed the possible electrode-gel parameters according to their main characteristics including size, shape and materials for the electrodes, and also the required chemical composition and volume of the gel.

It should be noted that, these parameters are mainly for HD-tDCS type and the electrodes of the conventional type are completely different, as they are simple sponge pads containing rubber electrodes (figure 4) and soaked in a saline solution (NaCl 0.9%)(Ben Taib & Manto, 2009).

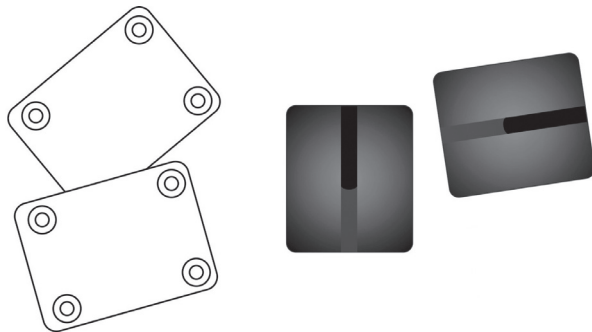

Figure 4. Sponge Pads (left) containing rubber electrodes (right)

Various pad shapes and sizes have been tested to rebut the common opinion of a considerable difference in electrical stimulation's tolerance ((Forrester BJ, Petrofsky JS., 2004). Moreover, the application of NaCl solutions in the range of 15 to 140 mM to sponge electrodes is



Figure 5. Different solid-conductor shapes and materials (Ag pellet, Ag/AgCl pellet, rubber pellet, Ag/AgCl ring, Ag/AgCl disc respectively).

11. TCS Montages

A tCS montage is a protocol determining the state of the stimulator device either in active or sham mode. Among protocol's parameters, the most important is the electrode positioning which depends on the goal and design of the study. Typically, there are two types of position-

ing, bilateral and unilateral. Unlike the bilateral positioning in which both electrodes are placed on scalp, in unilateral, only the active electrode is placed on the scalp and the reference is placed mostly on supraorbital area or shoulder, contralateral to the active electrode (generally, in unilateral design the reference electrode can be placed anywhere except the scalp). In other words, bilateral

proven to possibly cause no pain to the subject and to be perceived as comfortable during the tDCS trial (Dundas, Thickbroom, & Mastaglia, 2007).

In fact, all these efforts are made to achieve the appropriate solid-conductor and to partly guarantee the most desirable electrode durability, skin safety and subjective pain. There have been some experiments related to HD-tDCS to discover the most appropriate electrodes for stimulation, as items have recently been examined in well-designed investigations.

A collection of five types of solid-conductor (figure 5) (Ag pellet, Ag/AgCl pellet, rubber pellet, Ag/AgCl ring and Ag/AgCl disc) and seven conductive gels (Signa, Spectra, Tensive, Redux, BioGel, Lectron and CCNY-4) were identified and examined. Finally, the Ag/AgCl ring in combination with CCNy-4 gel resulted in the most favorable outcomes.

Under anode stimulation, electrode potential and temperature rises generally occurred in all electrode-gel combinations except for both Ag and rubber pellet electrodes with Signa and CCNY-4 gels. Sensation results however, are shown to be independent of stimulation polarity (whether to use anode or cathode).

Ag/AgCl ring electrodes were found to be the most comfortable followed by Ag, rubber and Ag/AgCl pellet electrodes across all gels(Minhas, et al.).

stimulation can be performed with the two electrodes (anode and cathode) on analogous regions of the right and left hemisphere while the unilateral montage comprises positioning the active electrode on the DLPFC and the cathode on the contralateral supraorbital.

Of note, Nitsche et al., have provided an overview of the recent studies introducing different aspects of their protocols as well as details on their montage (Nitsche et al., 2008). Placing the stimulation electrode on M1 or hand area and the reference electrode on the contralateral orbit alters the brain activity of the subjects depending on the polarity of stimulation. As noted, with cathode being the active electrode, the excitability of the involved area reduces, while anodal excitability enhances after the anodal stimulation in basic neurophysiology applications. Moreover, this montage can enhance β -band in motor cortical excitability after the anodal stimulation while it is reduced after the cathodal one using the intramuscular coherence analysis (Power et al., 2006). While using anode as the active electrode, placing the stimulation electrode on S1 and the reference on contralateral orbit is shown to result in laser-evoked pain perception diminution in cathode stimulation and improve the spatial acuity. Active electrode on Oz and the reference on Cz results in visual perception threshold elevation using the cathodal stimulation (Antal, Nitsche, & Paulus, 2001) and reduction in phosphine threshold by anodal stimulation (Antal, Kincses, Nitsche, & Paulus, 2003).

When placing anode on Cp5 and the reference electrode on the contralateral orbit, the stimulation leads to an enhancement in language learning (Floel, Rosser, Michka, Knecht, & Breitenstein, 2008).

Studies with unilateral vs. bilateral electrode positioning have reemphasized the importance of the reference electrode's position in later analyses. The positioning of electrodes is normally based on the 10-20 international EEG system which is represented in figure 6.

12. Safety Concerns

Currently, the required current for stimulation is 1 to 2 mA at maximum and the clinical devices usually guarantee not to exceed this level to let the procedure remain innocuous for the patients. When applying a 1 mA direct current via two electrodes of 7x5 cm in size, the amount of the electrical current will predict an axial and tangential cortical current density of approximately 0.093 A/m² and 0.090 A/m², respectively, (Zaghi, Acar, Hultgren, Boggio, & Fregni).

Despite a common concern assuming the process probably dangerous, it generally does not cause considerable adverse effects, although it has some, including decreased heat and cold sensory thresholds and a marginal analgesic effect for cold pain thresholds when using HD-tDCS technique. No meaningful effects on mechanical pain thresholds and heat pain thresholds are usually

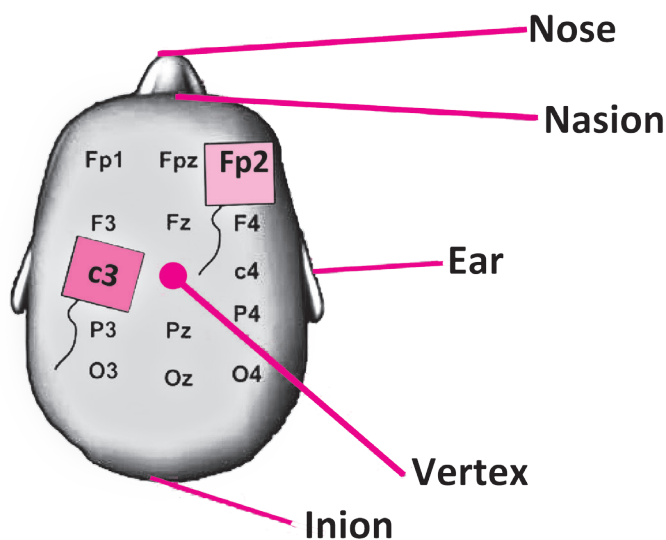

NEUROSCIENCE

Figure 6. The 10-20 International EEG system is used to determine electrodes placement. For instance, to perform the anodal stimulation of dorsolateral prefrontal cortex the anode (active electrode) should be placed over F3 or F4 depending on the study.

observed(Borckardt, et al.). In the conventional type, a group of healthy subjects and patients were examined to determine what kind of TCS-related problems they may report. The most common reported adverse effect turned out to be the tingling sensation. In addition, the light itching sensation under the stimulating electrodes was considered as an undesirable effect. However, after the stimulation, infrequent headache, nausea and insomnia were rated as negative effects. The former sets of effects had mainly influenced the healthy group, while the latter were mostly reported by the patients(Poreisz, Boros, Antal, & Paulus, 2007).

13. Methodological Design for TCS Studies

Typically the design of a study TCS-involved is a straightforward procedure in which the main target is generating reliable and valid data in order to measure the effects of TCS in a certain neurocognitive function. There are some critical questions (Figure 7) which must be answered in order to create a study design based on an a priori hypothesis and the main question. We have created a diagram based on these critical questions (CQ) to show the roadmap of a complete methodological design of such a study (Figures 7 to 9).



NEURSCIENCE

Figure 7. The critical questions which need to be answered to generate a roadmap when designing a TCS-included study. Red boxes are the brief descriptions of each bold phrase, which is the important keywords of each critical question.

13.1. The Roadmap

A normal study-design consists of six major steps (Figure 8), which would be based on the hypothesis and the main goals of the study. The first step is the answer to the critical questions 1 to 3. Generally, there are two main types of studies: studies with single (e.g. Normal People) or multiple target populations (e.g. Normal Con-

trols and Alzheimer's Patients). Normally, if the purpose of a study is to investigate the effects of TCS in different conditions (for instance the hypothesis that TCS exerts positive effects on working memory performance in normal people), single-target is the method of choice. On the other hand, when the purpose is to determine differences of TCS procedure effects in different targets (for example, the hypothesis that TCS increases work-

ing memory performance in Alzheimer's patients with better efficacy compared to normal subjects), the second method (two target populations) should be applied. Whether we choose single-target or multiple-targets, the rest of the roadmap is mostly the same; however, in order to generate appropriate comparable data in a multiple-target design, we must divide it into the same number of separate single-target designs and compare their data to make the final decision of the experiment. This division brings on the sample matching concern, which means all the samples should be two by two matched.

After specifying the target populations we have to decide on the neurocognitive function of interest and its assessment method. Behavioral methods (e.g. Questionnaires) and brain mapping techniques (e.g. EEG) are two types of assessments could be used alongside TCS. The last process of this step is determining the region of interest (ROI) on the brain. Most of the time results from previous TCS or TMS studies are used to find the appropriate region to intervene.

13.2. Intervention Types

The second step is to choose the intervention types to use in the study, which is directly related to the critical questions 4 through 6. This step is divided into three inner steps illustrated in the second box of Figure 8. "Active" and "Control" are the two categories of intervention types which their specification should be fixed in the first (CQ 4, 5) and second (CQ 6) inner steps, respectively.

In the first inner step we have to specify the active interventions from two available choices; anodal and cathodal, and after that to determine the place of reference electrode based on the "Electrode Montage" in which we should choose montage of electrodes placement from three types of montages: 1: Double Monopolar Montage in which two active electrodes (contralateral to each other) would be placed on the scalp and one reference electrode outside the scalp. 2: Monopolar Montage which is the same as the first type with only one active electrode on the scalp. 3: Bipolar Montage in which both active and reference electrodes would be placed on the scalp.

The second inner step is to decide on the control interventions. There are two types of control interventions: "Active Control" and "Sham Control". Active control refers to an intervention different from (but with regard to) the active intervention, which divides into three types: different stimulation of the same region (e.g. if the active intervention is anodal over F3, a possible active control could be cathodal over F3); same stimulation of

the contralateral region (e.g. if active intervention is anodal over F3, a possible active control could be anodal over F4); same stimulation of another region (e.g. anodal over F3 for active and anodal over O4 for control).

Considering all types of the available active and control interventions, combinations of a variety of them seems possible however, only one of these combinations (permutations) would be used in a study, which suggests that we must choose this combination carefully and make a decision based on our hypothesis, goal and previously published articles. After specifying the "combination of interventions", we then have to decide on the electrodes location according to brain regions. We should find their exact position based on landmarks or an international standard in order to be comparable with other studies. MRI-guided measures and international the 10-20 standard for electrode positioning are the two systems which are widely used in intervention studies. Final part is about specifying the size of each electrode. Normally, 5 x 5 or 5 x 7 cm² electrodes are used.

13.3. Session Design

Session Design is the third step in the process of designing a TCS study. In this step, the procedure of each session and the experimental protocols of the study should be designed to give answer to the seventh critical question. At first, the target TCS effect should be determined which is the outcome of our decision on incorporating offline, online or mix of both protocols.

In an online protocol, the assessment procedure is performed during the intervention, which requires counter-balanced (across subjects) sessions with respect to the intervention types in order to generate enough data for measuring the effects of intervention during a certain cognitive process. In contrast, the assessment task in the offline type is performed either post to intervention or in a pre-post procedure meaning that it would be performed both before and after the intervention. The combination of offline and online designs is another possibility which is a good candidate for an advanced procedure design as we can measure the effects of both the stimulation and assessment tasks at the same time. Mostly, in this type of design, online stimulation is conducted immediately after offline one or vice versa (e.g. ten minutes of offline stimulation followed by ten minutes of online stimulation).

13.4. Stimulation Protocol

In this step (Forth step), the technical settings of stimulator should be set. At first, one should decide whether

to use alternating or direct current and then distinguish the current features (intensity for direct currents and intensity and frequency for alternating currents). Then the duration of the intervention, which is divided into stimulation time and ramping time, should be defined.

13.5. Blindness

The fifth step is about our approach to blind the study, which is a response to the CQ 9. Typically, blindness means putting subjects, examiners and/or analysts unaware of the intervention types of each session in order to be able to measure “placebo effects”. Blindness comes in three levels: the single-blinded design, means that only subjects are blinded to the conditions while double blind means that in addition to subjects, examiners are also blinded and triple-blinded means that all subjects, examiners and data analysts are blinded to the conditions.

13.6. Study Type and Analysis Model

The final step (Step 6) is dedicated to our decision about using “multiple groups” or “multiple sessions” design for the each target population in the study and is a response to CQ 10. In a “multiple groups” design, at first several groups should be defined based on the intervention types selected in previous steps (i.e. if the intervention types are active anodal and sham control, we should define two groups: one for active anodal and the other for sham control intervention) after which the random samples (subjects) from the target population must be assigned to each group. This procedure implicitly encompasses a case control study. Unlike multiple groups, in multiple sessions we would deal with only one group in which for each intervention type at least one session per subject is needed. This design leads to a crossover study with randomized sessions with respect to intervention types. Each one of these designs has its pros and cons, meanwhile the major concerns in multiple sessions are the carryover effect and habituation. Knowing the probable effects of intervention could help us to get around the carryover effect, but in order to deal wisely with the habituation problem we must choose the assessment task cautiously.

The output of a TCS study strongly depends on the statistical methods which show whether there are significant differences between Active and Control results. Therefore, the final decision (Inference and Outcome) in a study design depends on its statistical analysis model. We have to extract all the random variables generated by our choices in previous steps and create a statistical model based on them. Two simple and widely used statistical models are Student t-test and ANOVA.

13.7. Multiple Stimulations

All we explained in this section so far is about designing a research study, but what should we do to use TCS in clinical practice? Unfortunately, there is no comprehensive answer to this question and further studies are needed to create a universal protocol, but because a clinical protocol requires at least a multiple stimulation design, we decided to analyze the assumptions and requirements of multiple stimulation studies. There are three assumptions about TCS in a multiple stimulation design, explained in figure 9: Accumulativeness of TCS effects, Escalation in TCS effect durability and Time dependence of TCS therapeutic effects.

14. TCS as a Method of Choice for Neurocognitive Studies

There have been abundant studies investigating the efficacy of the tDCS which mostly intend to reach to the clinical application chances to be used as treatment. TDCS could also be used during the basic cognitive studies to provide causal inferences regarding the functional human brain mapping in both normal and clinical population. TDCS as a safe and inexpensive intervention method has received serious attention from different cognitive laboratories. But, non-focal and distributed electrical stimulation of tDCS in both superficial and deep brain regions made regional functional inferences very hard. There is a wide spectrum of cognitive functions under investigation with regard to the potential effects of TCS. Different methodological settings and “unpublished negative findings” have left some inconsistencies between the available evidences in different cognitive domains. nevertheless, there remain serious hopes for using TCS as a safe and portable cognitive modifier in a near future (Ekhtiari & Bashir, 2010).

15. TCS as a Method of Choice for Treatment

There have been some therapeutic results in some experiments in this field; hence this method has offered hope for being efficacious and safe in some clinical applications.

Possible clinical applications mainly include Parkinson’s disease, tinnitus, fibromyalgia, epilepsy, migraine, fluent aphasia and post-stroke motor deficits (Been, Ngo, Miller, & Fitzgerald, 2007). It might also be useful to apply this method to treat some psychological disorders such as depression, anxiety disorders and schizophrenia.

In PD (Parkinson’s disease), tDCS has been demonstrated as a beneficial way to affect the working memory inpatients depending upon the intensity and the site of stimulation which is justified by the local increase in excitability(Boggio, et al., 2006). In treating (focal) epilepsy both tDCS and rTMS have been used to directly affect the neocortical (epileptogenic) area

to result in an impermanent reduction in seizures’ frequency, usually lasting to several weeks(Paulus, 2009). Additionally, some recent studies have revealed that, the cathodal tDCS will be a good choice for treating epilepsy and dystonia(Nitsche, et al., 2003). Some experiments have also suggested that the cathodal tDCS over V1 might be an effective prophylactic therapy in mi-

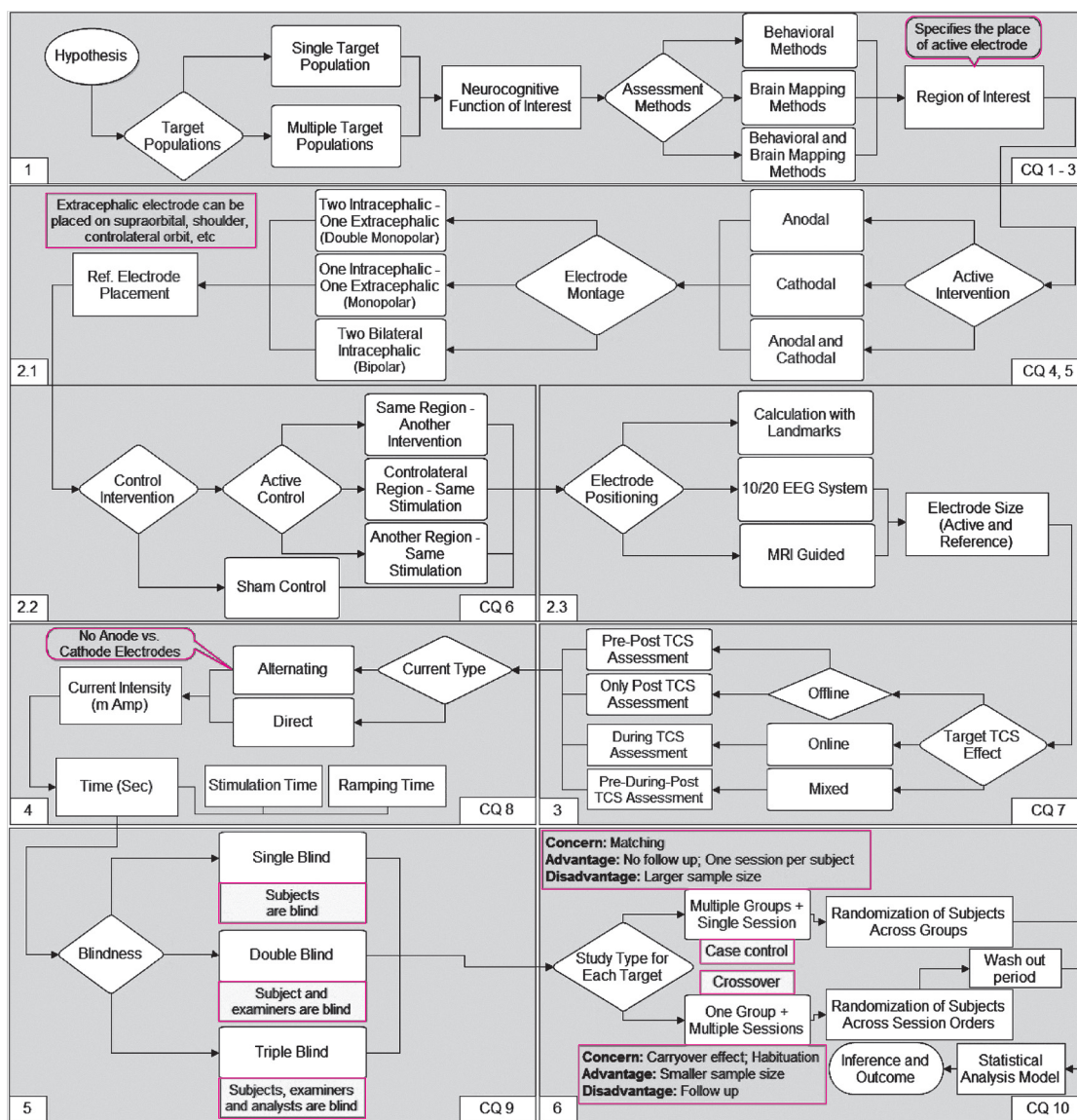

Figure 8. The roadmap to design a study which measures TCS effects in six steps: 1. Concept Design: Determining the total number of the target populations, which separates study into two directions: single target population vs. multiple-targets population in which each target should be dealt with separately as a single-target study (Critical Question (CQ) 1-3), then specifying neurocognitive function of interest, its assessment method, and region of interest. 2. Intervention Types: Choosing the intervention type to use in the procedure. 2.1. Specifying Active intervention (CQ 4) and reference electrode placement base on Electrode Montage. 2.2. Choosing a combination of control interventions (CQ 5). 2.3. Positioning the electrodes on the head based on a standard system and specifying the size of each electrode. 3. Session Design: Designing the procedure of each session based on our choice for the Target TCS Effect. 4. Stimulation Protocol: Setting the stimulator’s properties such as current intensity (CQ 8). 5. Blindness: Clarifying the blindness status of the people involved in the experiment (CQ 9). 6. Study Design: Determination of single group vs. multiple groups design, its randomization and the statistical model to analyze the results.

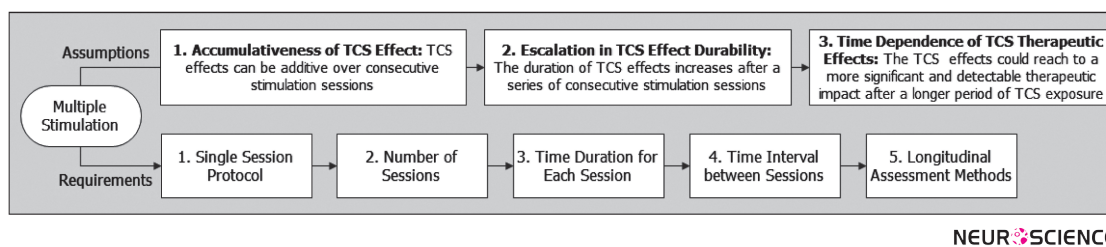

Figure 9. Assumptions and requirements in a multiple stimulation study design.

graine and this is perhaps according to the pain control (Antal, Kriener, Lang, Boros, & Paulus). With regard to the putative positive effects anodal tDCS may have on the aphasic patients, a study has depicted a meaningful improvement in language treatment due to a decreased processing time during a picture naming task by the fluent aphasic participants, when administering anodal tDCS on the left hemisphere of head (Fridriksson, Richardson, Baker, & Rorden). Recently, researchers have made a significant progress, stressing alterations in resting membrane potential, spontaneous neural firing rates, synaptic strength, cerebral blood flow and metabolism subsequent to the tDCS which portrays a potential avenue in near future due to the meaningful positive effects on major depressive disorder (MDD) (Arul-Anandam & Loo, 2009).

16. Future

As any field of application of tDCS has been experimental and not clinical until today, there are many possible chances for tDCS to flourish in treating both neuropathic and neurocognitive disorders in the near future (Bashir, Sikaroudi, Kazemi, Forough, & Ekhtiari, 2010). Although tDCS was temporarily forgotten due to fast paced progress in pharmacotherapy and other types of brain stimulation, it has started to revive again. Given the fact that TCS is much simpler and more available than any other types and requires only a direct current supply and some electrodes, this modality has found its way toward clinical applications. These methods generally include the same as mentioned in the previous section varying mainly in neuropsychological disorders. Thus, future studies can be correlated with molecular, neurophysiological and imaging techniques in order to determine the optimized solution for each disorder, in cases of current strength, durability, polarity and potential combinations with other types of brain stimulations or pharmacological interventions. As such, neuroimaging techniques are a possible way of finding the correlation between the individualized effects of the tDCS on the brain and the stimulation itself with varying properties. There are also

some studies to verify the computational phantom's role in predicting the current distribution in different brain areas during tDCS and this may lead to provide insights on a more accurate prediction of the involved brain regions. On the other hand, since HD-tDCS is one of the demanding fields on which there have not been sufficient investigations, it might be a great chance to carry out more studies in order to discover its efficacy, even further than the conventional type. Furthermore, this tool can be potentially beneficial to enhance language and mathematical abilities, concentration, problem solving, working memory and coordination as it facilitates the more accurate and justified modulation of the brain activity.

17. Conclusion

In conclusion, TCS is a safe, portable, noninvasive and painless method of brain modulation in which the alteration of brain excitability is intended through transmitting a small amount of current, direct or alternating, through a determined area of the brain. This intervention leads to a change in neural membrane potentials based on the polarity of the applied electrodes. Considering the ease, availability and tolerability of TCS for brain activity modulation, this modality has played a crucial role in offering hope to treat different types of neurocognitive disorders as compared to the other neuromodulation methods. Thus, there are a variety of commercial devices and other amenities which encourage researchers to run carefully designed pilot studies. There are several potential clinical applications for this technique based on which current studies are making progress to establish approved therapeutic interventional approaches to treat refractory neurocognitive disorders.

References

- Antal, A., Kincses, T. Z., Nitsche, M. A., & Paulus, W. (2003). Manipulation of phosphene thresholds by transcranial direct current stimulation in man. *Exp Brain Res*, 150(3), 375-378.
- Antal, A., Kriener, N., Lang, N., Boros, K., & Paulus, W. Cathodal transcranial direct current stimulation of the visual cortex in the prophylactic treatment of migraine. *Cephalalgia*, 31(7), 820-828.
- Antal, A., Nitsche, M. A., & Paulus, W. (2001). External modulation of visual perception in humans. *Neuroreport*, 12(16), 3553-3555.
- Arfai, E., Theano, G., Montagu, J. D., & Robin, A. A. (1970). A controlled study of polarization in depression. *Br J Psychiatry*, 116(533), 433-434.
- Arul-Anandam, A. P., & Loo, C. (2009). Transcranial direct current stimulation: a new tool for the treatment of depression? *J Affect Disord*, 117(3), 137-145.
- Arul-Anandam, A. P., Loo, C., & Sachdev, P. (2009). Transcranial direct current stimulation - what is the evidence for its efficacy and safety? *F1000 Med Rep*, 1.
- Bashir, S., Sikaroudi, H., Kazemi, R., Forough, B., & Ekhtiari, H. (2010). Integrated Technologies Like Noninvasive Brain Stimulation (NIBS) for Stroke Rehabilitation; New Hopes for Patients, Neuroscientists, and Clinicians in Iran. [Original]. *Basic and Clinical Neuroscience*, 1(4), 6-14.
- Baudewig, J., Nitsche, M. A., Paulus, W., & Frahm, J. (2001). Regional modulation of BOLD MRI responses to human sensorimotor activation by transcranial direct current stimulation. *Magn Reson Med*, 45(2), 196-201.
- Been, G., Ngo, T. T., Miller, S. M., & Fitzgerald, P. B. (2007). The use of tDCS and CVS as methods of non-invasive brain stimulation. *Brain Res Rev*, 56(2), 346-361.
- Ben Taib, N. O., & Manto, M. (2009). Trains of transcranial direct current stimulation antagonize motor cortex hypoexcitability induced by acute hemicerebellectomy. *J Neurosurg*, 111(4), 796-806.
- Bindman, L. J., Lippold, O. C., & Redfearn, J. W. (1962). Long-lasting changes in the level of the electrical activity of the cerebral cortex produced by polarizing currents. *Nature*, 196, 584-585.
- Bindman, L. J., Lippold, O. C., & Redfearn, J. W. (1964). The Action of Brief Polarizing Currents on the Cerebral Cortex of the Rat (1) During Current Flow and (2) in the Production of Long-Lasting after-Effects. *J Physiol*, 172, 369-382.
- Bishop, G. H., & O'Leary, J. L. (1950). The effects of polarizing currents on cell potentials and their significance in the interpretation of central nervous system activity. *Electroencephalogr Clin Neurophysiol*, 2(4), 401-416.
- Boggio, P. S., Ferrucci, R., Rigonatti, S. P., Covre, P., Nitsche, M., Pascual-Leone, A., et al. (2006). Effects of transcranial direct current stimulation on working memory in patients with Parkinson's disease. *J Neurol Sci*, 249(1), 31-38.
- Boggio, P. S., Khoury, L. P., Martins, D. C., Martins, O. E., de Macedo, E. C., & Fregni, F. (2009). Temporal cortex direct current stimulation enhances performance on a visual recognition memory task in Alzheimer disease. *J Neurol Neurosurg Psychiatry*, 80(4), 444-447.
- Boggio, P. S., Nunes, A., Rigonatti, S. P., Nitsche, M. A., Pascual-Leone, A., & Fregni, F. (2007). Repeated sessions of noninvasive brain DC stimulation is associated with motor function improvement in stroke patients. *Restor Neurol Neurosci*, 25(2), 123-129.
- Boggio, P. S., Rigonatti, S. P., Ribeiro, R. B., Myczkowski, M. L., Nitsche, M. A., Pascual-Leone, A., et al. (2008). A randomized, double-blind clinical trial on the efficacy of cortical direct current stimulation for the treatment of major depression. *Int J Neuropsychopharmacol*, 11(2), 249-254.
- Boggio, P. S., Sultani, N., Fecteau, S., Merabet, L., Mecca, T., Pascual-Leone, A., et al. (2008). Prefrontal cortex modulation using transcranial DC stimulation reduces alcohol craving: a double-blind, sham-controlled study. *Drug Alcohol Depend*, 92(1-3), 55-60.
- Borckardt, J. J., Bikson, M., Frohman, H., Reeves, S. T., Datta, A., Bansal, V., et al. A pilot study of the tolerability and effects of high-definition transcranial direct current stimulation (HD-tDCS) on pain perception. *J Pain*, 13(2), 112-120.
- Butson, C. R., & McIntyre, C. C. (2006). Role of electrode design on the volume of tissue activated during deep brain stimulation. *J Neural Eng*, 3(1), 1-8.
- Capel, I. D., Dorrell, H. M., Spencer, E. P., & Davis, M. W. (2003). The amelioration of the suffering associated with spinal cord injury with subperception transcranial electrical stimulation. *Spinal Cord*, 41(2), 109-117.
- Chaieb, L., Antal, A., Terney, D., & Paulus, W. Pharmacological modulation of the short-lasting effects of antagonistic direct current-stimulation over the human motor cortex. *Front Psychiatry*, 3, 67.
- Costain, R., Redfearn, J. W., & Lippold, O. C. (1964). A Controlled Trial of the Therapeutic Effect of Polarization of the Brain in Depressive Illness. *Br J Psychiatry*, 110, 786-799.
- Dundas, J. E., Thickbroom, G. W., & Mastaglia, F. L. (2007). Perception of comfort during transcranial DC stimulation: effect of NaCl solution concentration applied to sponge electrodes. *Clin Neurophysiol*, 118(5), 1166-1170.
- Ekhtiari, H., & Bashir, S. (2010). Brain Stimulation Technology in Addiction Medicine; Main Problems Waiting for Solutions. [Original]. *Basic and Clinical Neuroscience*, 1(4), 3-4.
- Ferrucci, R., Mameli, F., Guidi, I., Mrakic-Sposta, S., Vergari, M., Marceglia, S., et al. (2008). Transcranial direct current stimulation improves recognition memory in Alzheimer disease. *Neurology*, 71(7), 493-498.
- Feurra, M., Galli, G., & Rossi, S. (2012). Transcranial alternating current stimulation affects decision making. *Front Syst Neurosci*, 6, 39.
- Floel, A., Rosser, N., Michka, O., Knecht, S., & Breitenstein, C. (2008). Noninvasive brain stimulation improves language learning. *J Cogn Neurosci*, 20(8), 1415-1422.
- Fregni, F., Boggio, P. S., Nitsche, M. A., Marcolin, M. A., Rigonatti, S. P., & Pascual-Leone, A. (2006). Treatment of major depression with transcranial direct current stimulation. *Bipolar Disord*, 8(2), 203-204.
- Fregni, F., Boggio, P. S., Santos, M. C., Lima, M., Vieira, A. L., Rigonatti, S. P., et al. (2006). Noninvasive cortical stimulation with transcranial direct current stimulation in Parkinson's disease. *Mov Disord*, 21(10), 1693-1702.

- Fregni, F., Orsati, F., Pedrosa, W., Fecteau, S., Tome, F. A., Nitsche, M. A., et al. (2008). Transcranial direct current stimulation of the prefrontal cortex modulates the desire for specific foods. *Appetite*, 51(1), 34-41.
- Fregni, F., Thome-Souza, S., Nitsche, M. A., Freedman, S. D., Valente, K. D., & Pascual-Leone, A. (2006). A controlled clinical trial of cathodal DC polarization in patients with refractory epilepsy. *Epilepsia*, 47(2), 335-342.
- Fridriksson, J., Richardson, J. D., Baker, J. M., & Rorden, C. Transcranial direct current stimulation improves naming reaction time in fluent aphasia: a double-blind, sham-controlled study. *Stroke*, 42(3), 819-821.
- Gabis, L., Shklar, B., & Geva, D. (2003). Immediate influence of transcranial electrostimulation on pain and beta-endorphin blood levels: an active placebo-controlled study. *Am J Phys Med Rehabil*, 82(2), 81-85.
- Gimsa, J., Habel, B., Schreiber, U., van Rienen, U., Strauss, U., & Gimsa, U. (2005). Choosing electrodes for deep brain stimulation experiments—electrochemical considerations. *J Neurosci Methods*, 142(2), 251-265.
- Griskova, I., Hoppner, J., Ruksenas, O., & Dapsys, K. (2006). Transcranial magnetic stimulation: the method and application. *Medicina (Kaunas)*, 42(10), 798-804.
- Gross, C. G. (2007). The discovery of motor cortex and its background. *J Hist Neurosci*, 16(3), 320-331.
- Hall, K. M., Hicks, R. A., & Hopkins, H. K. (1970). The effects of low level DC scalp positive and negative current on the performance of various tasks. *Br J Psychiatry*, 117(541), 689-691.
- Hesse, S., Werner, C., Schonhardt, E. M., Bardeleben, A., Jenrich, W., & Kirker, S. G. (2007). Combined transcranial direct current stimulation and robot-assisted arm training in subacute stroke patients: a pilot study. *Restor Neurol Neurosci*, 25(1), 9-15.
- Hummel, F., Celnik, P., Giraux, P., Floel, A., Wu, W. H., Gerloff, C., et al. (2005). Effects of non-invasive cortical stimulation on skilled motor function in chronic stroke. *Brain*, 128(Pt 3), 490-499.
- Hummel, F. C., Voller, B., Celnik, P., Floel, A., Giraux, P., Gerloff, C., et al. (2006). Effects of brain polarization on reaction times and pinch force in chronic stroke. *BMC Neurosci*, 7, 73.
- Iyer, M. B., Mattu, U., Grafman, J., Lomarev, M., Sato, S., & Wassermann, E. M. (2005). Safety and cognitive effect of frontal DC brain polarization in healthy individuals. *Neurology*, 64(5), 872-875.
- Kanai, R., Chaieb, L., Antal, A., Walsh, V., & Paulus, W. (2008). Frequency-dependent electrical stimulation of the visual cortex. *Curr Biol*, 18(23), 1839-1843.
- Knoch, D., Nitsche, M. A., Fischbacher, U., Eisenegger, C., Pascual-Leone, A., & Fehr, E. (2008). Studying the neurobiology of social interaction with transcranial direct current stimulation—the example of punishing unfairness. *Cereb Cortex*, 18(9), 1987-1990.
- Lang, N., Siebner, H. R., Ward, N. S., Lee, L., Nitsche, M. A., Paulus, W., et al. (2005). How does transcranial DC stimulation of the primary motor cortex alter regional neuronal activity in the human brain? *Eur J Neurosci*, 22(2), 495-504.
- Liebetanz, D., Nitsche, M. A., Tergau, F., & Paulus, W. (2002). Pharmacological approach to the mechanisms of transcranial DC-stimulation-induced after-effects of human motor cortex excitability. *Brain*, 125(Pt 10), 2238-2247.
- Lifshitz, K., & Harper, P. (1968). A trial of transcranial polarization in chronic schizophrenics. *Br J Psychiatry*, 114(510), 635-637.
- Lippold, O. C., & Redfearn, J. W. (1964). Mental Changes Resulting from the Passage of Small Direct Currents through the Human Brain. *Br J Psychiatry*, 110, 768-772.
- Marshall, L., Molle, M., Siebner, H. R., & Born, J. (2005). Bifrontal transcranial direct current stimulation slows reaction time in a working memory task. *BMC Neurosci*, 6, 23.
- Minhas, P., Bansal, V., Patel, J., Ho, J. S., Diaz, J., Datta, A., et al. Electrodes for high-definition transcutaneous DC stimulation for applications in drug delivery and electrotherapy, including tDCS. *J Neurosci Methods*, 190(2), 188-197.
- Monti, A., Cogiamanian, F., Marceglia, S., Ferrucci, R., Mameli, F., Mrakic-Spota, S., et al. (2008). Improved naming after transcranial direct current stimulation in aphasia. *J Neurol Neurosurg Psychiatry*, 79(4), 451-453.
- Mrakic-Spota, S., Marceglia, S., Mameli, F., Dilena, R., Tadini, L., & Priori, A. (2008). Transcranial direct current stimulation in two patients with Tourette syndrome. *Mov Disord*, 23(15), 2259-2261.
- Nekhendzy, V., Lemmens, H. J., Tingle, M., Nekhendzy, M., & Angst, M. S. (2010). The analgesic and antihyperalgesic effects of transcranial electrostimulation with combined direct and alternating current in healthy volunteers. *Anesth Analg*, 111(5), 1301-1307.
- Nitsche, M. A., Cohen, L. G., Wassermann, E. M., Priori, A., Lang, N., Antal, A., et al. (2008). Transcranial direct current stimulation: State of the art 2008. *Brain Stimul*, 1(3), 206-223.
- Nitsche, M. A., Fricke, K., Henschke, U., Schlitterlau, A., Liebetanz, D., Lang, N., et al. (2003). Pharmacological modulation of cortical excitability shifts induced by transcranial direct current stimulation in humans. *J Physiol*, 553(Pt 1), 293-301.
- Nitsche, M. A., & Paulus, W. (2000). Excitability changes induced in the human motor cortex by weak transcranial direct current stimulation. *J Physiol*, 527 Pt 3, 633-639.
- Paulus, W. (2009). International conference on transcranial magnetic and direct current stimulation. *Dtsch Arztebl Int*, 106(9), 143-144.
- Pauly, P. J. (1983). The political structure of the brain: cerebral localization in Bismarckian Germany. *Int J Neurosci*, 21(1-2), 145-149.
- Poreisz, C., Boros, K., Antal, A., & Paulus, W. (2007). Safety aspects of transcranial direct current stimulation concerning healthy subjects and patients. *Brain Res Bull*, 72(4-6), 208-214.
- Power, H. A., Norton, J. A., Porter, C. L., Doyle, Z., Hui, I., & Chan, K. M. (2006). Transcranial direct current stimulation of the primary motor cortex affects cortical drive to human musculature as assessed by intermuscular coherence. *J Physiol*, 577(Pt 3), 795-803.

- Priori, A. (2003). Brain polarization in humans: a reappraisal of an old tool for prolonged non-invasive modulation of brain excitability. *Clin Neurophysiol*, 114(4), 589-595.
- Rango, M., Cogiamanian, F., Marceglia, S., Barberis, B., Arighi, A., Biondetti, P., et al. (2008). Myoinositol content in the human brain is modified by transcranial direct current stimulation in a matter of minutes: a 1H-MRS study. *Magn Reson Med*, 60(4), 782-789.
- Redfearn, J. W., Lippold, O. C., & Costain, R. (1964). A Preliminary Account of the Clinical Effects of Polarizing the Brain in Certain Psychiatric Disorders. *Br J Psychiatry*, 110, 773-785.
- Roizenblatt, S., Fregni, F., Gimenez, R., Wetzel, T., Rigonatti, S. P., Tufik, S., et al. (2007). Site-specific effects of transcranial direct current stimulation on sleep and pain in fibromyalgia: a randomized, sham-controlled study. *Pain Pract*, 7(4), 297-306.
- Roy-Byrne, P., Craske, M. G., Sullivan, G., Rose, R. D., Edlund, M. J., Lang, A. J., et al. Delivery of evidence-based treatment for multiple anxiety disorders in primary care: a randomized controlled trial. *Jama*, 303(19), 1921-1928.
- Schroeder, M. J., & Barr, R. E. (2001). Quantitative analysis of the electroencephalogram during cranial electrotherapy stimulation. *Clin Neurophysiol*, 112(11), 2075-2083.
- Southworth, S. (1999). A study of the effects of cranial electrical stimulation on attention and concentration. *Integr Physiol Behav Sci*, 34(1), 43-53.
- Speer, A. M., Kimbrell, T. A., Wassermann, E. M., J. D. R., Willis, M. W., Herscovitch, P., et al. (2000). Opposite effects of high and low frequency rTMS on regional brain activity in depressed patients. *Biol Psychiatry*, 48(12), 1133-1141.
- Tan, G., Rintala, D. H., Thornby, J. I., Yang, J., Wade, W., & Vasiliev, C. (2006). Using cranial electrotherapy stimulation to treat pain associated with spinal cord injury. *J Rehabil Res Dev*, 43(4), 461-474.
- Tehovnik, E. J. (1996). Electrical stimulation of neural tissue to evoke behavioral responses. *J Neurosci Methods*, 65(1), 1-17.
- Wagner, T., Fregni, F., Fecteau, S., Grodzinsky, A., Zahn, M., & Pascual-Leone, A. (2007). Transcranial direct current stimulation: a computer-based human model study. *Neuroimage*, 35(3), 1113-1124.
- Wagner, T., Valero-Cabre, A., & Pascual-Leone, A. (2007). Non-invasive human brain stimulation. *Annu Rev Biomed Eng*, 9, 527-565.
- Yoo, S. S., Bystritsky, A., Lee, J. H., Zhang, Y., Fischer, K., Min, B. K., et al. (2011). Focused ultrasound modulates region-specific brain activity. *Neuroimage*, 56(3), 1267-1275.
- Zaehle, T., Rach, S., & Herrmann, C. S. (2010). Transcranial alternating current stimulation enhances individual alpha activity in human EEG. *PLoS One*, 5(11), e13766.
- Zaghi, S., Acar, M., Hultgren, B., Boggio, P. S., & Fregni, F. Noninvasive brain stimulation with low-intensity electrical currents: putative mechanisms of action for direct and alternating current stimulation. *Neuroscientist*, 16(3), 285-307.
- Zhang, J., Laiwalla, F., Kim, J. A., Urabe, H., Van Wagenen, R., Song, Y. K., et al. (2009). Integrated device for optical stimulation and spatiotemporal electrical recording of neural activity in light-sensitized brain tissue. *J Neural Eng*, 6(5), 055007.